

Unique indexed tip technology.



NOZZLE TIP, VALVE PIN AND BUSHING INDEXED (WILL ALWAYS BE IN ACCURATE POSITION).

AESTHETICAL PARTS

- ✔ Smooth material flow
- ✔ No visible mark on part
- ✔ Excellent thermal barrier with tip

TECHNICAL PARTS

- ✔ Optimized wear resistance
- ✔ Preservation of fiber length
- ✔ Excellent thermal barrier with tip

PROCESS TO SELECT TIP

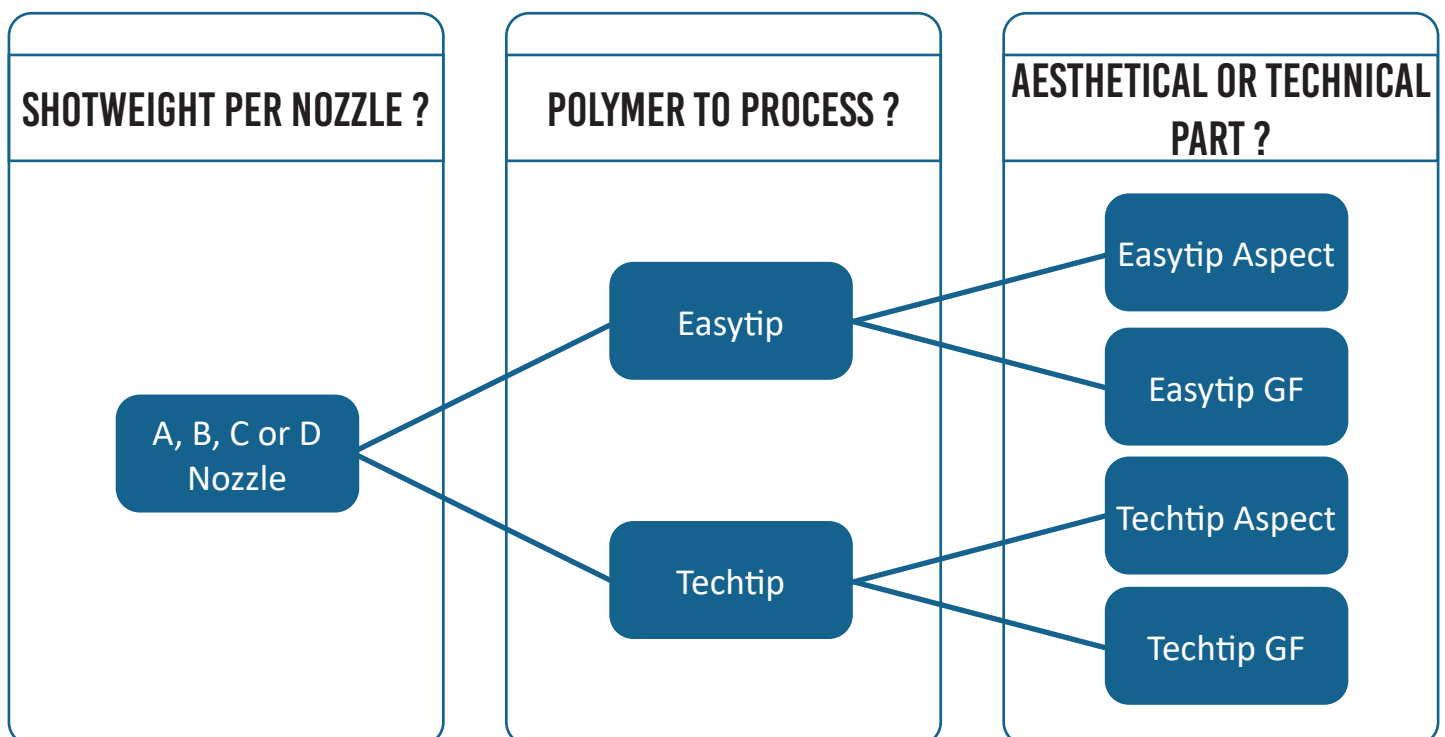

Nozzle D for the technical and small applications.

PRODUCT HIGHLIGHTS

- Injection capacity : 10 to 180 cm³ per nozzle
- Available for Open nozzles and Valve gates

FEATURES OF THE MODULFLOW NOZZLE D

- Compact thickness : 105 mm with clamping plate included and **maximum mold support**
- No cooling water required for usual materials
- Monozone or multizone heatings
- Available with hydraulic or pneumatic cylinders

SPECIFICATIONS

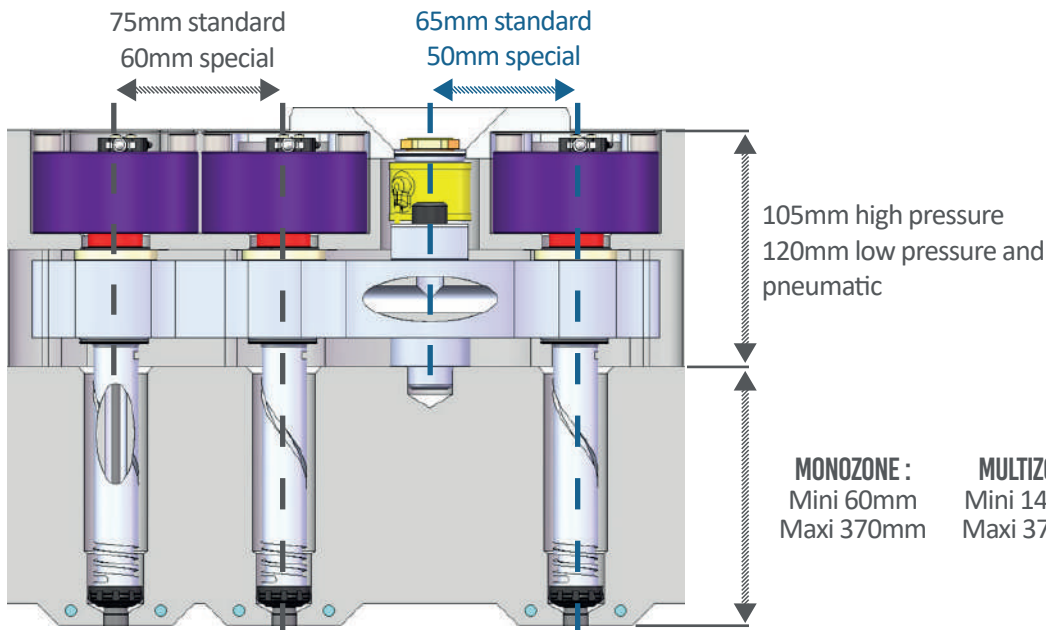

HYDRAULIC VERSION

