

Cabletrunk solution for sequential hot runner systems.

Optimax is a prewired, prepiped system which includes the mechanical, thermal and hydraulic / pneumatic components.

PRODUCT HIGHLIGHTS

- ✔ Cylinders are offset with nozzles : no cooling required
- ✔ Maximum mold support (outside mold cavity cable trunk design)
- ✔ Nozzle tip, valve pin and bushing indexed (will always be in accurate position)
- ✔ 100 bar, 50 bar and pneumatic
- ✔ Easy assembly and maintenance with rigid cabletrunk + columns option
- ✔ High performance tip technology for aesthetical or glass fiber reinforced parts

HYDRAULIC ELECTROVALVE INCLUDING:
oil filter, led, pressure regulator, manometer

COMPACT THICKNESS : 125 MM (4.921")

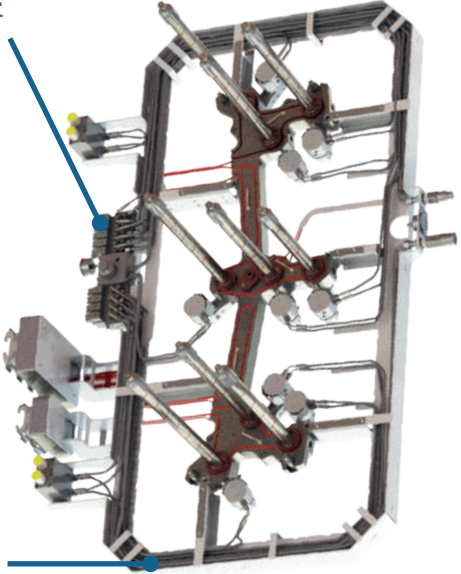

1 000 000 cycles warranty on mechanism



New ceramic, no wear axis
1 000 000 cycles warranty

Colorex plug implementation possible / Needle guide designed for technical materials / Improved sealed needle guide for PP



Position sensor

RHEOLOGY

Standard diameters to suit all injection needs.

NOZZLE A:

Ø 22 & 24 mm
Needle Ø 8 mm
Gate Ø 8 mm

NOZZLE B:

Ø 16, 18, 21 mm
Needle Ø 6 mm
Gate Ø 4, 5, 6 mm

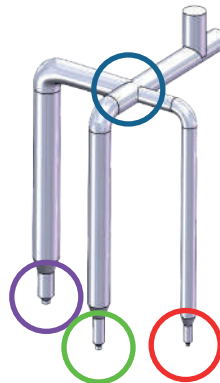

MANIFOLD:

Ø 8, 10, 12, 14, 16,
18, 20, 22 mm

NOZZLE C:

Ø 10, 12, 14 mm
Needle Ø 5,5 mm
Gate Ø 2, 3, 4 mm

COMPACT DESIGN

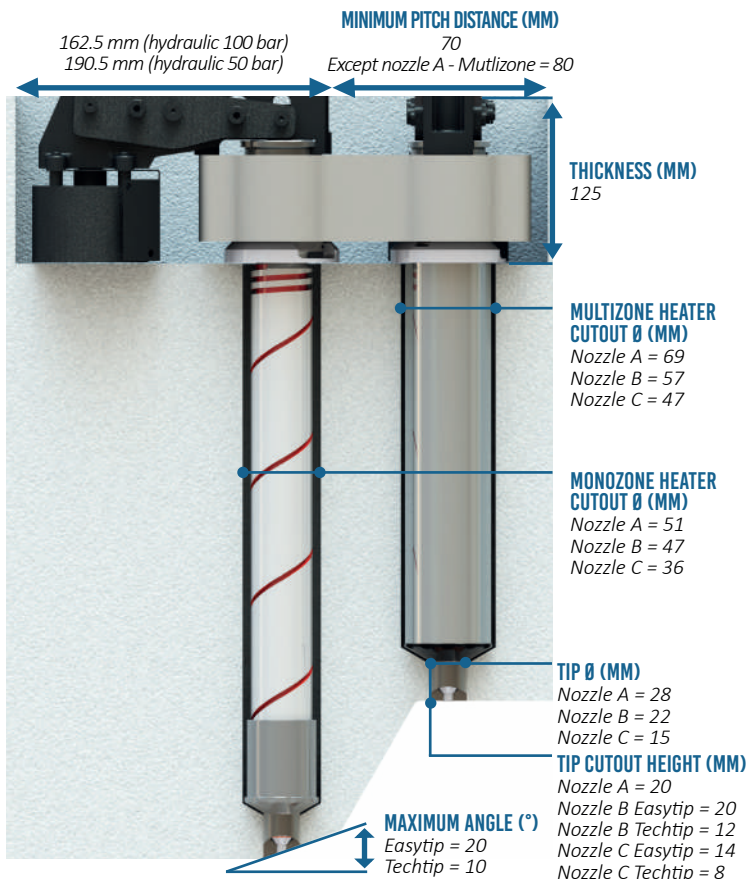

Many standard solutions have been developed to suit all injection situations:

- 2k molds
- Fast color change
- Increase L/Z ratio
- Flow Control, Flow Driver
- Lateral injection