

The nozzle D for the technical applications with reduced weight.

PRODUCTS HIGHLIGHTS

- Injection capacity : 10 to 180 cm³ per nozzle
- Available for Open nozzles and Valve gates

FEATURES OF THE MODULFLOW NOZZLE D

- Compact thickness** : 105 mm with clamping plate included and **maximum mold support**
- No cooling water required for usual materials
- Monozone and multizone heatings (nozzles)
- Available with hydraulic or pneumatic cylinders
- Suitable for standard and technical materials and process with color change available

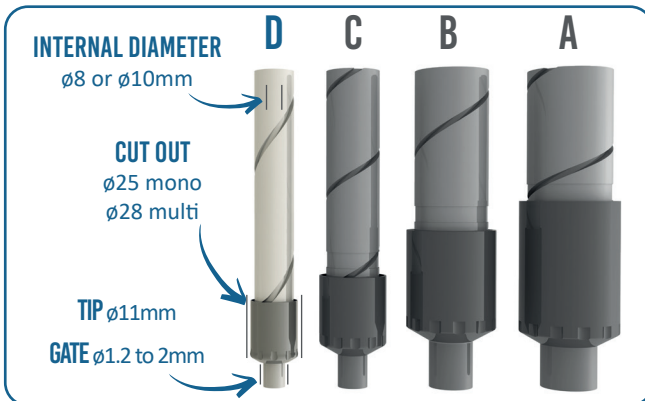

FEATURES & LAYOUT

