

Flow CONTROL

- ALLOWS EFFICIENT CONTROL OVER FLOW MARKS
- COST EFFECTIVE HYDRAULIC SOLUTION
- 100% EMBEDDED ON THE HOT RUNNER SYSTEM
- DOES NOT REQUIRE ANY COMPLEX AND EXPENSIVE EXTERNAL DEVICE / OPTION AVAILABLE ON VALVE GATED PRODUCT RANGES
- PROGRESSIVE GATE OPENING IS AVAILABLE ONLY FOR EASYTIP BUSHINGS FOR PP BASED APPLICATIONS (DIAM: 4 MM ONLY)

WITHOUT FLOWCONTROL :

PRESSURE DROP RESPONSIBLE FOR FLOW MARKS

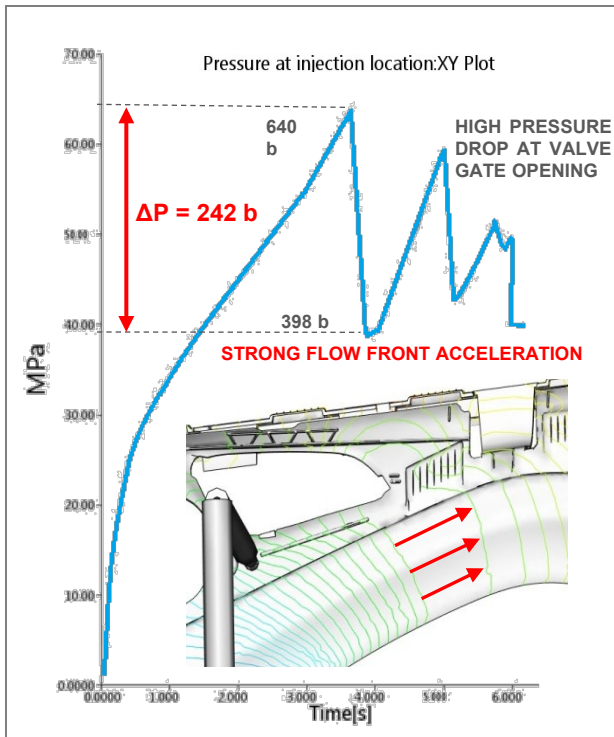

WITH FLOWCONTROL :

ELIMINATION OF THE FLOW MARKS

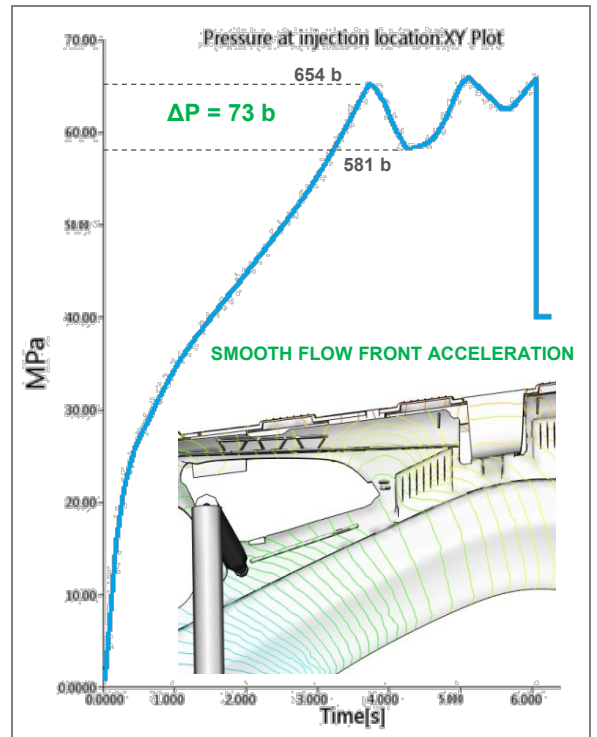

OPTION 1 : INDIVIDUAL GATE SPEED OPENING CONTROL USING THE HIGH PRECISION HYDRAULIC FLOW CONTROL DEVICE

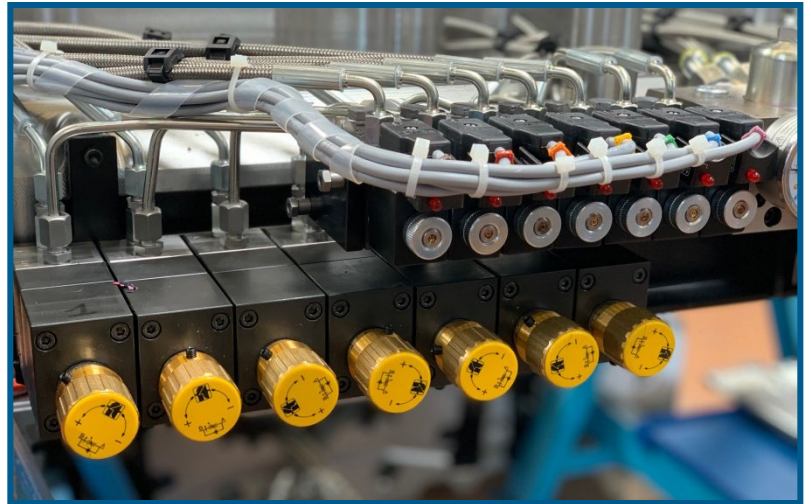

OPTION 2 : PROGRESSIVE GATE TIP TECHNOLOGY (NOT AVAILABLE FOR COLOR CHANGE)

**OPENING START
SLOW FLOW**

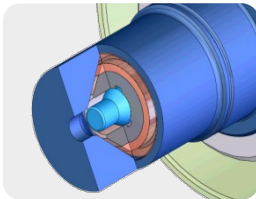

**MIDDLE STROKE
MEDIUM FLOW**

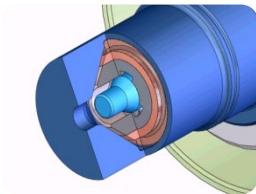

**FULL STROKE
FULL FLOW**

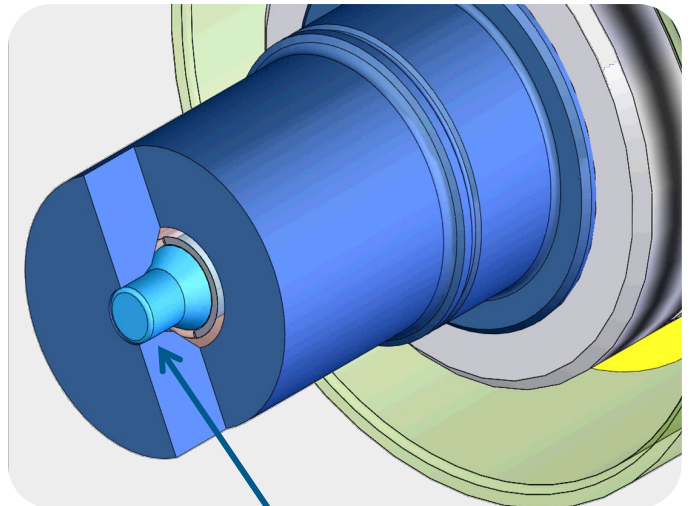
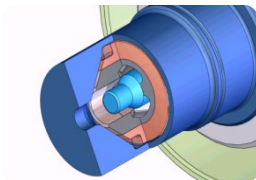

CYLINDRICAL GATE CLOSING :

- ☑ LONG LIFE
- ☑ PERFECT GATE QUALITY
- ☑ GUIDED NEEDLE